



Desander Cyclone and Sand Accumulator

technical specifications

Equipment Weights & Dimensions

Structure Weight	2,265 kg
Operating Weight	2,348 kg
Unit Length	1,727 mm
Unit Width	1,100 mm
Unit Height	5,027 mm
Footprint Area	1.90 m ²
Deck Loading	1236 kg/m ²

Pressure and Temperatures

Design Pressure	1,200 psi
Design Temperature	93°C



WATER TREATMENT



CETCO
OILFIELD
SERVICES
COMPANY

UK
Malaysia
Middle East
Africa
Australia

+44(0)1224 787340
+603 216 206 95
+968 245 80219
+44(0)791 783 8316
+61(0) 893 160122

www.cetcooilfieldservices.com

PRELIMINARY

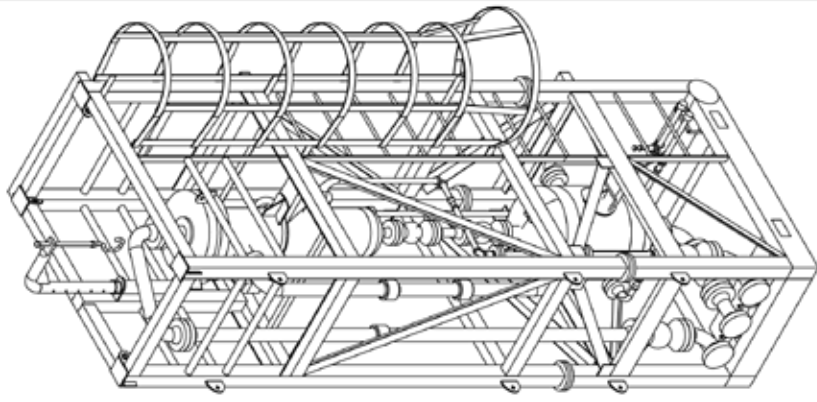
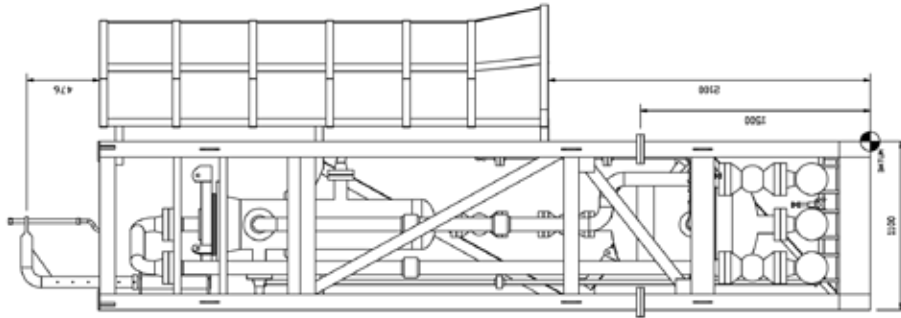
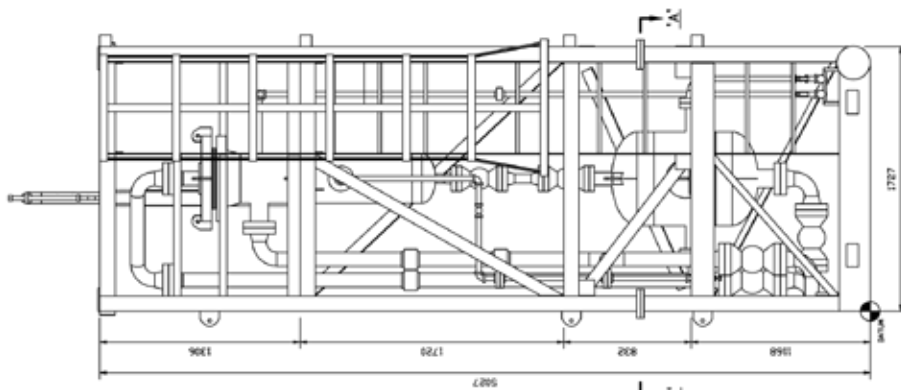
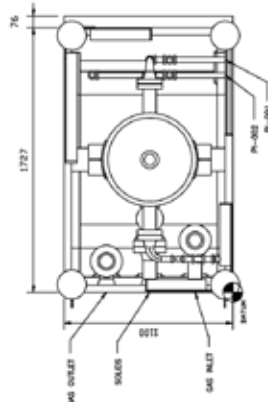
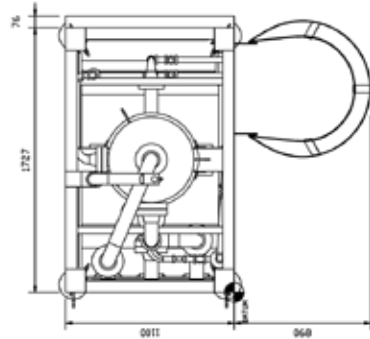
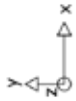

NOTES:

REFERENCE DRAWING TITLE

NO.	DATE	REVISIONS	BY	CHKD.	NO.	REVISIONS	BY	CHKD.

PROJECT NO.	
DATE	
SCALE	
PROJECT TITLE	DISASSEMBLY CYCLONE & ACCUMULATOR GENERAL ARRANGEMENT
DESIGNED BY	
CHECKED BY	
DATE	
PROJECT NO.	
DATE	
SCALE	
PROJECT TITLE	DISASSEMBLY CYCLONE & ACCUMULATOR GENERAL ARRANGEMENT
DESIGNED BY	
CHECKED BY	
DATE	

cetcooilfieldservices.com

