



Drilling Waste Treatments - Applications for Environmental Compliance and Waste Minimisation

- Completion Fluids Filtration
- Brine Filtration
- Well Test Returns
- Acid Flow Backs
- Slops Tank Fluid Treatments
- Well Abandonment
- Produced Water

Recent Applications Include

- H₂S elimination from well flow back & stimulation activities in Kazakhstan
- Acid flow back treatments Statoil-Slepiner and Amerada Hess - Triton
- Brine filtration Chevron
- Cooling medium treatment BHP Billiton and BP Miller
- Well abandonment cleanup Coflexip Stena/Amerada Hess
- Zinc bromide segregation Chevron
- Oily brines & calcium bromide recovery/treatment - BP
- Completion fluids cleanup Chevron
- Well stimulation cleanup Schlumberger-Tullow Oil
- Solids filtration AJS Shell Leman
- 6,000 m² wastewater with 1,000 m³ LSA sludge contaminated with biomass & oil treatment - Maersk NSP
- 98% solids removal using CrudeSep® BP Schiehallion

Kazakhstan - CETCO Equipment Setup

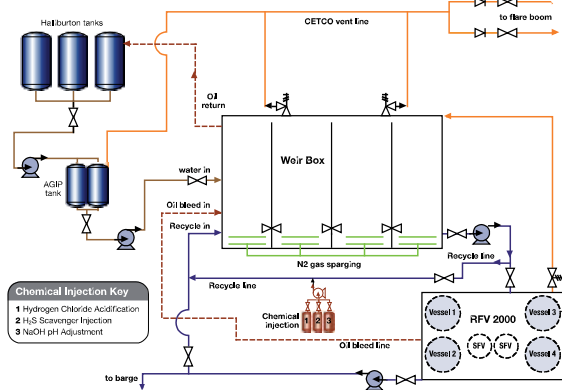

Typical Weirbox and CrudeSorb® Setup with Sparging Chemical Dosing

WATER TREATMENT



CETCO
OILFIELD
SERVICES

UK +44(0)1224 787340
 Malaysia +603 216 206 95
 Middle East +968 245 80219
 Africa +44(0)791 783 8316
 Australia +61(0) 893 160122

cetcooilfieldservices.com